

## Basic Lead Pattern (Minor Pentatonic Scale)

This lesson will introduce Intermediate guitar players to a very basic, but popular Lead Pattern (The Minor Pentatonic Scale). Whether or not you choose to pursue lead playing at a higher level – all guitarists should at least understand the basics of lead playing.

A lead pattern is a basic pattern or scale that is used as a guide in making up leads and melodies. It basically gives you a look at which notes to use while playing a lead. This pattern has a root note (the Key) and moves up and down the fretboard (as do barre chords) so it can be played in any Key.

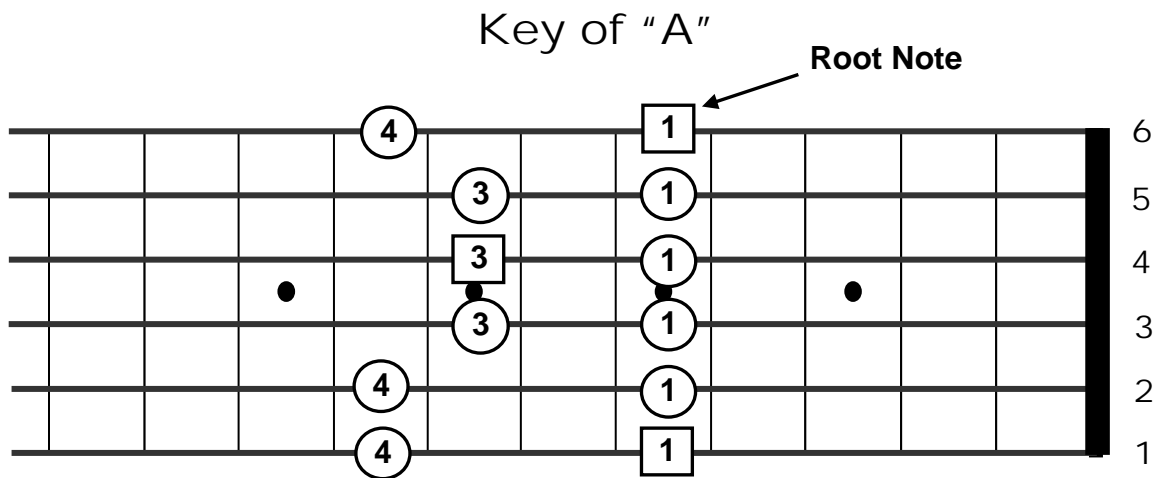

**\*How to practice this lead pattern:** Start with your 1<sup>st</sup> finger on the 5<sup>th</sup> fret of the 6<sup>th</sup> string (top string – fattest string), then your 4<sup>th</sup> finger on the 8<sup>th</sup> fret of the 6<sup>th</sup> string (top string). Then move to the next string with your 1<sup>st</sup> finger on the 5<sup>th</sup> fret of the 5<sup>th</sup> string, then your 3<sup>rd</sup> finger on the 7<sup>th</sup> fret of the 5<sup>th</sup> string. Then move to the next string with your 1<sup>st</sup> finger on the 5<sup>th</sup> fret of the 4<sup>th</sup> string, then your 3<sup>rd</sup> finger on the 7<sup>th</sup> fret of the 4<sup>th</sup> string, (and so on...). Play all the strings until you get to the bottom string – then start at the bottom and play all the strings until you get back to the top string again. To start back up play the notes in reverse. Start with your 4<sup>th</sup> finger on the 8<sup>th</sup> fret of the 1<sup>st</sup> string, then your 1<sup>st</sup> finger on the 5<sup>th</sup> fret of the 1<sup>st</sup> string. Then move to the next string up with your 4<sup>th</sup> finger on the 8<sup>th</sup> fret of the 2<sup>nd</sup> string, then your 1<sup>st</sup> finger on the 5<sup>th</sup> fret of the 2<sup>nd</sup> string. Then move to the next string up with your 3<sup>rd</sup> finger on the 7<sup>th</sup> fret of the 3<sup>rd</sup> string, then your 1<sup>st</sup> finger on the 5<sup>th</sup> fret of the 3<sup>rd</sup> string (and so on...). Get a good sound from each note as you play it.

**\* Picking sequence** – It is very important that you use the proper picking sequence right from the beginning. Alternate Picking down then up: The first note (5<sup>th</sup> fret of the 6<sup>th</sup> string) is picked down, then the second note (8<sup>th</sup> fret of the 6<sup>th</sup> string) is picked up, and so on... Always alternate the picking sequence down, then up.

**Note:** This picking sequence should not be “neglected” and should be utilized to get the best results.

This lead pattern may be a little difficult at first, but after lots of practice it will become easier. Start slow, at this stage you are only trying to get a “clean” sound from each of the notes. If you try to go too fast, it will take longer to learn properly. It will take a little time for your left hand to sync up with your right hand. Take your time...